

# DIESEL GENERATOR SET

## MTU 6R0120 DS200

200 kWe / 60 Hz / Standby  
208 - 600V

Reference MTU 6R0120 DS200 (180 kWe) for Prime Rating Technical Data



### SYSTEM RATINGS

#### Standby

Voltage (L-L)	240V	240V	208V	240V	380V	480V	600V
Phase	1	1	3	3	3	3	3
PF	1	1	0.8	0.8	0.8	0.8	0.8
Hz	60	60	60	60	60	60	60
kW	200	200	200	200	200	200	200
kVA	200	200	250	250	250	250	250
Amps	833	833	694	601	380	301	241
skVA@30%							
Voltage Dip	268	366	433	433	373	577	512
Generator							
Model	432CSL6210	432PSL6228	431CSL6206	431CSL6206	431CSL6208	431CSL6206	431PSL6243
Temp Rise	130 °C/40 °C	130 °C/40 °C	130 °C/40 °C	130 °C/40 °C	130 °C/40 °C	130 °C/40 °C	130 °C/40 °C
Connection	12 LEAD DOUBLE DELTA	4 LEAD	12 LEAD WYE	12 LEAD DELTA	12 LEAD WYE	12 LEAD WYE	4 LEAD WYE

### CERTIFICATIONS AND STANDARDS

// **Emissions** – EPA Tier 3 Certified

// **Generator set is designed and manufactured in facilities certified to standards ISO 9001:2008 and ISO 14001:2004**

// **Seismic Certification** – Optional

- IBC Certification
- OSHPD Pre-Approval

// **Power Rating**

- Accepts Rated Load in One Step Per NFPA 110

// **UL 2200 / CSA** – Optional

- UL 2200 Listed
- CSA Certified
- CE Marking Provided

// **Performance Assurance Certification (PAC)**

- Generator Set Tested to ISO 8528-5 for Transient Response
- Verified product design, quality and performance integrity
- All engine systems are prototype and factory tested

## STANDARD FEATURES\*

- // MTU Onsite Energy is a single source supplier
  - // Global Product Support
  - // 2 Year Standard Warranty
  - // OM926LA Diesel Engine
    - 7.2 Liter Displacement
    - 4-Cycle
  - // Engine-generator resilient mounted
  - // Complete Range of Accessories
- // Generator
    - Brushless, Rotating Field Generator
    - 2/3 Pitch Windings
    - 300% Short Circuit Capability with Optional Permanent Magnet Generator (PMG)
  - // Digital Control Panel(s)
    - UL Recognized, CSA Certified, NFPA 110
    - Complete System Metering
    - LCD Display
  - // Cooling System
    - Integral Set-Mounted
    - Engine-Driven Fan

## STANDARD EQUIPMENT\*

### // Engine

Air Cleaners  
 Oil Pump  
 Oil Drain Extension and S/O Valve  
 Full Flow Oil Filter  
 Fuel Filter with Water Separator  
 Jacket Water Pump  
 Thermostat  
 Blower Fan and Fan Drive  
 Radiator - Unit Mounted  
 Electric Starting Motor - 12V  
 Governor - Electronic Isochronous  
 Base - Formed Steel  
 SAE Flywheel and Bell Housing  
 Charging Alternator - 12V  
 Battery Box and Cables  
 Flexible Fuel Connectors  
 Flexible Exhaust Connection  
 EPA Certified Engine

### // Generator

NEMA MG1, IEEE and ANSI standards compliance for temperature rise and motor starting  
 Self-Ventilated and Drip-Proof  
 Superior Voltage Waveform  
 Solid State, Volts-per-Hertz Regulator  
 ±1% Voltage Regulation No Load to Full Load Regulation

Brushless Alternator with Brushless Pilot Exciter  
 4 Pole, Rotating Field  
 130 °C Max. Standby Temperature Rise  
 1 Bearing, Sealed  
 Flexible Coupling  
 Full Amortisseur Windings  
 125% Rotor Balancing  
 3-Phase Voltage Sensing  
 100% of Rated Load - One Step  
 5% Max. Total Harmonic Distortion

### // Digital Control Panel(s)

Digital Metering  
 Engine Parameters  
 Generator Protection Functions  
 Engine Protection  
 SAE J1939 Engine ECU Communications  
 Windows®-Based Software  
 Multilingual Capability  
 Remote Communications to RDP-110 Remote Annunciator  
 Programmable Input and Output Contacts  
 UL Recognized, CSA Certified, CE Approved  
 Event Recording  
 IP 54 Front Panel Rating with Integrated Gasket  
 NFPA 110 Compatible

\* Represents standard product only. Consult Factory/MTU Onsite Energy Distributor for additional configurations.

## APPLICATION DATA

### // Engine

Manufacturer	Mercedes-Benz
Model	OM926LA
Type	4-Cycle
Arrangement	6-Inline
Displacement: L (in <sup>3</sup> )	7.2 (439)
Bore: cm (in)	10.6 (4.17)
Stroke: cm (in)	13.6 (5.35)
Compression Ratio	17.5:1
Rated RPM	1,800
Engine Governor	MR2 / ADM3
Max. Power: kWm (bhp)	247 (331)
Speed Regulation	±0.25%
Air Cleaner	Dry

### // Liquid Capacity (Lubrication)

Total Oil System: L (gal)	29 (7.7)
Engine Jacket Water Capacity: L (gal)	10 (2.6)
System Coolant Capacity: L (gal)	24.1 (6.4)

### // Electrical

Electric Volts DC	12
Cold Cranking Amps Under -17.8 °C (0 °F)	950

### // Fuel System

Fuel Supply Connection Size	-6 JIC
Fuel Supply Hose Size	3/8" ID
Fuel Return Connection Size	-6 JIC
Fuel Return Hose Size	3/8" ID
Max. Fuel Lift: m (ft)	2.6 (8.5)
Recommended Fuel	Diesel #2
Total Fuel Flow: L/hr (gal/hr)	330.5 (87.3)

### // Fuel Consumption \*

At 100% of Power Rating: L/hr (gal/hr)	55.3 (14.6)
At 75% of Power Rating: L/hr (gal/hr)	40.5 (10.7)
At 50% of Power Rating: L/hr (gal/hr)	26.5 (7)

\* Based on 431CSL6206 480 Volt generator set

### // Cooling - Radiator System

Ambient Capacity of Radiator: °C (°F)	50 (122)
Max. Restriction of Cooling Air: Intake and Discharge Side of Rad.: kPa (in. H <sub>2</sub> O)	0.12 (0.5)
Water Pump Capacity: L/min (gpm)	143 (37)
Heat Rejection to Coolant: kW (BTUM)	95.5 (5,431)
Heat Rejection to Air to Air: kW (BTUM)	55.3 (3,145)
Heat Radiated to Ambient: kW (BTUM)	40.8 (2,322)
Fan Power: kW (hp)	15.6 (22.1)

### // Air Requirements

Aspirating: *m <sup>3</sup> /min (SCFM)	14.8 (523)
Air Flow Required for Rad.	
Cooled Unit: *m <sup>3</sup> /min (SCFM)	408 (14,408)
Remote Cooled Applications; Air Flow Required for Dissipation of Radiated Generator Set Heat for a Max. of 25 °F Rise: *m <sup>3</sup> /min (SCFM)	149.2 (5,269)

\* Air density = 1.184 kg/m<sup>3</sup> (0.0739 lbm/ft<sup>3</sup>)

### // Exhaust System

Gas Temp. (Stack): °C (°F)	520 (968)
Gas Volume at Stack	
Temp: m <sup>3</sup> /min (CFM)	44.8 (1,582)
Max. Allowable	
Back Pressure: kPa (in. H <sub>2</sub> O)	10.5 (42)

## WEIGHTS AND DIMENSIONS

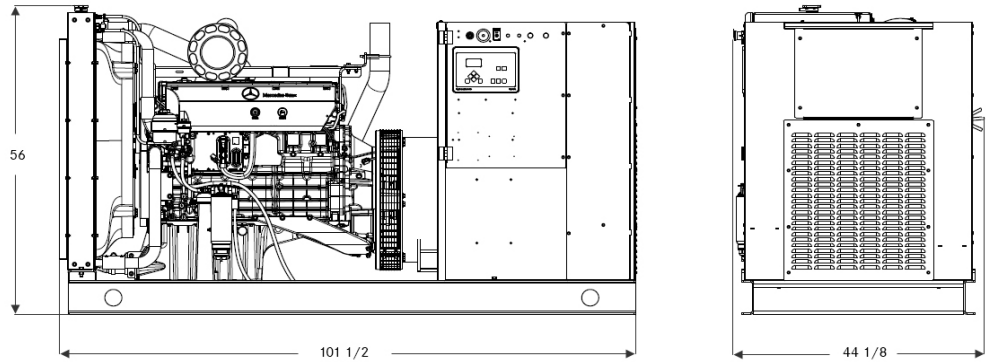

Drawing above for illustration purposes only, based on standard open power 480 volt generator set. Lengths may vary with other voltages. Do not use for installation design. See website for unit specific template drawings.

System	Dimensions (L x W x H)	Weight (less tank)
Open Power Unit (OPU)	2,580 x 1,121 x 1,422 mm (101.57 x 44.13 x 56 in)	1,632-2,120 kg (3,598-4,674 lb)

Weights and dimensions are based on open power units and are estimates only. Consult the factory for accurate weights and dimensions for your specific generator set.

## SOUND DATA

Unit Type	Standby Full Load
Level 0: Open Power Unit dB(A)	88.9

Sound data is provided at 7 m (23 ft). Generator set tested in accordance with ISO 8528-10 and with infinite exhaust.

## EMISSIONS DATA

NO <sub>x</sub> + NMHC	CO	PM
3.93	1.2	0.06

**All units are in g/hp-hr and shown at 100% load (not comparable to EPA weighted cycle values).** Emission levels of the engine may vary with ambient temperature, barometric pressure, humidity, fuel type and quality, installation parameters, measuring instrumentation, etc. The data was obtained in compliance with US EPA regulations. The weighted cycle value (not shown) from each engine is guaranteed to be within the US EPA Standards.

## RATING DEFINITIONS AND CONDITIONS

// Standby ratings apply to installations served by a reliable utility source. The standby rating is applicable to varying loads for the duration of a power outage. No overload capability for this rating. Ratings are in accordance with ISO 3046-1, BS 5514, and AS 2789. Average load factor: ≤ 85%.

// Deration Factor:

**Altitude:** Consult your local MTU Onsite Energy Power Generation Distributor for altitude derations.

**Temperature:** Consult your local MTU Onsite Energy Power Generation Distributor for temperature derations.

C/F = Consult Factory/MTU Onsite Energy Distributor

N/A = Not Available