



Gas Generator Set

mtu 10V0068 GS125

125 kWe/60 Hz/Standby/208 - 600V

System ratings

Voltage (L-L)	240V †	240V †	208V †	240V †	480V †	600V
Phase	1	1	3	3	3	3
PF	1	1	0.8	0.8	0.8	0.8
Hz	60	60	60	60	60	60
Natural Gas (NG)						
Amps	521	521	434	376	188	151
kW/kVA	125/125	125/125	125/156.25	125/156.25	125/156.25	125/156.25
Liquid Propane (LP)						
Amps	521	521	434	376	188	151
kW/kVA	125/125	125/125	125/156.25	125/156.25	125/156.25	125/156.25
NG and LP						
skVA@30% voltage Dip	196	130	323	323	430	331
Generator model	431PSL6224	431CSL6204	363CSL1607	363CSL1607	363CSL1607	363PSL1658
Temp rise	130 °C/40 °C	130 °C/40 °C	130 °C/40 °C	130 °C/40 °C	130 °C/40 °C	130 °C/40 °C
Connection	4 LEAD	12 LEAD DOUBLE DELTA	12 LEAD WYE	12 LEAD DELTA	12 LEAD WYE	4 LEAD WYE

† UL 2200 offered

Note: This unit is available with a dual fuel configuration.

Certifications and standards

- Generator set is designed and manufactured in facilities certified to standards ISO 9001:2008 and ISO 14001:2004
- Seismic certification – optional
 - 2018 IBC certification
 - OSHPD pre-approval
- UL 2200 – optional (refer to *System ratings* for availability)
- CSA – optional
 - CSA C22.2 No. 100
 - CSA C22.2 No. 14
- Performance Assurance Certification (PAC)
 - Generator set tested to ISO 8528-5 for transient response
 - Verified product design, quality and performance integrity
 - All engine systems are prototype and factory tested
- Power rating
 - Accepts rated load in one step per NFPA 110

Standard features*

- Single source supplier
- Global product support
- Two (2) Year/3,000 Hour Basic Limited Warranty
- 6.8LT CAC engine
 - 6.8 liter displacement
 - 4-cycle
- 3-way catalyst
- Optional fuels: LP liquid and dual fuel
- Engine-generator resilient mounted
- Complete range of accessories
- Cooling system
 - Integral set-mounted
 - Engine-driven fan
- Generator
 - Brushless, rotating field generator
 - 2/3 pitch windings
 - 300% short circuit capability with optional Permanent Magnet Generator (PMG)
- Digital control panel(s)
 - UL recognized, CSA Certified, NFPA 110
 - Complete system metering
 - LCD display

Standard equipment*

Engine

- Heavy duty air cleaner
- Oil pump
- Oil drain extension and shut-off valve
- Full flow oil filter
- Jacket water pump
- Thermostat
- Blower fan and fan drive
- Radiator - unit mounted
- Electric starting motor - 12V
- Governor - electronic isochronous
- Base - formed steel
- SAE flywheel and bell housing
- Charging alternator - 12V
- Battery rack and cables
- Flexible exhaust connection
- Liquid cooled, ball bearing turbcharger
- EPA certified engine

Generator

- NEMA MG1, IEEE, and ANSI standards compliance for temperature rise and motor starting
- Sustained short circuit current of up to 300% of the rated current for up to 10 seconds
- Self-ventilated
- Superior voltage waveform
- Solid state, volts-per-hertz regulator
- $\pm 1\%$ voltage regulation no load to full load
- Brushless alternator with brushless pilot exciter
- 4 pole, rotating field
- 130 °C maximum standby temperature rise
- 1-bearing, sealed
- Flexible coupling
- Full amortisseur windings
- 125% rotor balancing
- 3-phase voltage sensing
- 100% of rated load - one step
- 5% maximum total harmonic distortion

Digital control panel(s)

- Digital metering
- Engine parameters
- Generator protection functions
- Engine protection
- SAE J1939 engine ECU communications
- Windows®-based software
- Multilingual capability
- Communications to remote annunciator
- Programmable input and output contacts
- UL recognized, CSA certified, CE approved
- Event recording
- IP 54 front panel rating with integrated gasket
- NFPA 110 compatible

Application data

Engine

Manufacturer	mtu
Model	6.8LT CAC
Type	4-cycle
Aspiration	turbocharged, intercooled
Arrangement	10-V
Displacement: L (in ³)	6.8 (415)
Bore: cm (in)	9 (3.55)
Stroke: cm (in)	10.6 (4.17)
Compression ratio	9:1
Rated rpm	1,800
Engine governor	Bosch
Maximum power (NG): kWm (bhp)	154 (207)
Maximum power (LP): kWm (bhp)	154 (207)
Steady state frequency band	C/F
Air cleaner	dry

Liquid capacity

Total oil system: L (gal)	5.7 (1.5)
Engine jacket water capacity: L (gal)	6.1 (1.6)
System coolant capacity: L (gal)	35.04 (9.25)

Electrical

Electric volts DC	12
Cold cranking amps under -17.8 °C (0 °F)	925
Batteries: group size	31
Batteries: quantity	1

Fuel inlet - vaporous supply

Fuel supply connection size	1-1/2" NPT
Fuel supply pressure: mm H ₂ O (in. H ₂ O)	178-279 (7-11)

Fuel inlet - liquid supply

Fuel supply connection size	#6 (3/8") female SAE 45° flare
Maximum fuel supply pressure: kPa (PSI)	2,150 (312)

Fuel consumption (NG-1000 BTU/ft³ / LP-2500 BTU/ft³)

	NG	LPG
At 100% of power rating: m ³ /hr (ft ³ /hr)	41.4 (1,463)	18.1 (640)
At 75% of power rating: m ³ /hr (ft ³ /hr)	32.9 (1,161)	14.3 (505)
At 50% of power rating: m ³ /hr (ft ³ /hr)	24 (849)	10.4 (366)

Cooling - radiator system

	NG and LPG
Ambient capacity of radiator: °C (°F)	50 (122)*
Maximum restriction of cooling air: intake and discharge side of radiator: kPa (in. H ₂ O)	0.12 (0.5)
Water pump capacity: L/min (gpm)	123 (32.5)
Heat rejection to coolant: kW (BTUM)	85.3 (4,850)
Heat radiated to ambient: kW (BTUM)	39.82 (2,265)
Heat rejected to charge air cooler: kW (BTUM)	14.1 (800)
Fan power: kW (hp)	9.1 (12.2)

* Installation of enclosures reduces the ambient capacity of the cooling system by 3 °C (5.4 °F).

Air requirements

	NG and LPG
Aspirating: *m ³ /min (SCFM)	7.8 (275)
Air flow required for radiator cooled unit: *m ³ /min (SCFM)	256 (9,056)
Remote cooled applications; air flow required for dissipation of radiated generator set heat for a maximum of 25 °F rise: *m ³ /min (SCFM)	144.6 (5,107)

* Air density = 1.184 kg/m³ (0.0739 lbm/ft³)

Exhaust system

	NG and LPG
Gas temperature (stack): °C (°F)	649 (1,200)
Gas volume at stack temperature: m ³ /min (CFM)	25.1 (886)
Maximum allowable back pressure at outlet of engine, before piping: kPa (in. H ₂ O)	6.2 (25)

Weights and dimensions

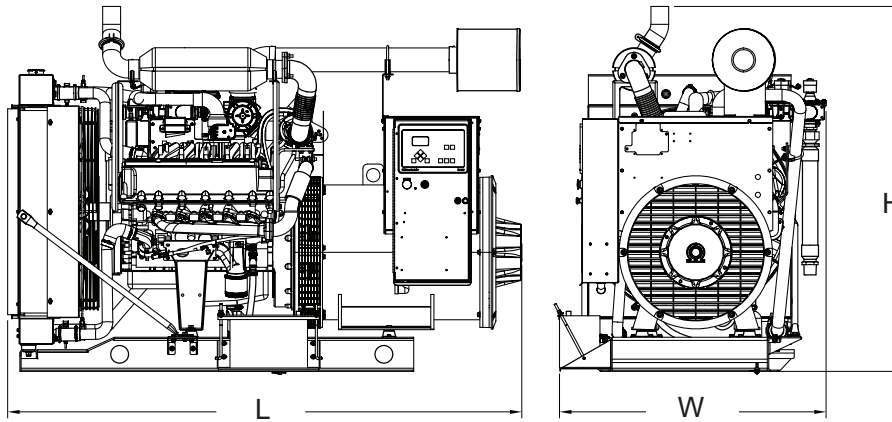

Drawing above for illustration purposes only, based on standard open power 480 volt generator set. Lengths may vary with other voltages. Do not use for installation design. See website for unit specific template drawings.

System	Dimensions (L x W x H)	Weight
Open Power Unit (OPU)	2,191 x 1,137 x 1,556 mm (86.3 x 44.8 x 61.3 in)	1,126–1,908 kg (2,482–4,207 lb)

Weights and dimensions are based on open power units and are estimates only. Consult the factory for accurate weights and dimensions for your specific generator set.

Sound data

Unit type	Standby full load (NG)	Standby full load (LP)
Level 0 (OPU): dB(A)	83	83

Sound data is provided at 7 m (23 ft). Generator set tested in accordance with ISO 8528-10 and with infinite exhaust.

Emissions data

Fuel type	THC + NO _x	CO
Natural gas	0.4	0.04
Liquid propane	0.11	0.16

- All units are in g/hp-hr and are EPA weighted cycle values. Emission levels of the engine may vary with ambient temperature, barometric pressure, humidity, fuel type and quality, installation parameters, measuring instrumentation, etc. The data was obtained in compliance with US EPA regulations.

Rating definitions and conditions

- Standby ratings apply to installations served by a reliable utility source. The standby rating is applicable to varying loads for the duration of a power outage. No overload capability for this rating. Ratings are in accordance with ISO 3046-1, BS 5514, and AS 2789. Average load factor: ≤ 85%.
- Nominal ratings at standard conditions: 25 °C and 300 meters (77 °F and 1,000 feet).
- Deration factor:
 - Consult your local **mtu** Distributor for altitude derations.
 - Consult your local **mtu** Distributor for temperature derations.

C/F = Consult Factory/**mtu** Distributor